

CAD FILE:

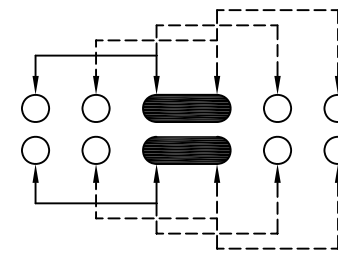

SCHMATIC(SHORTING)

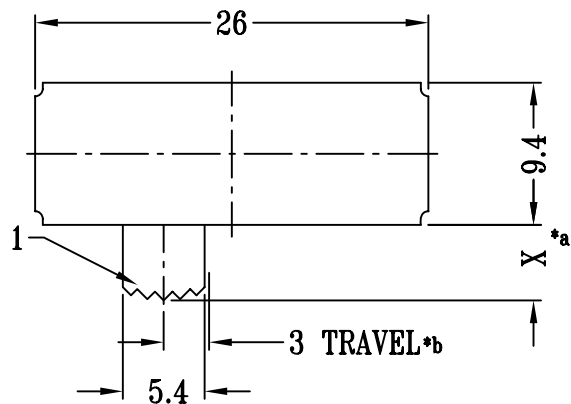
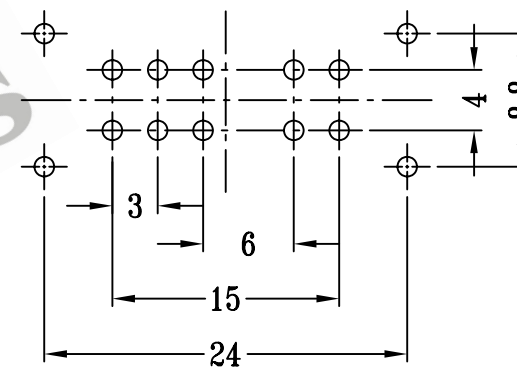
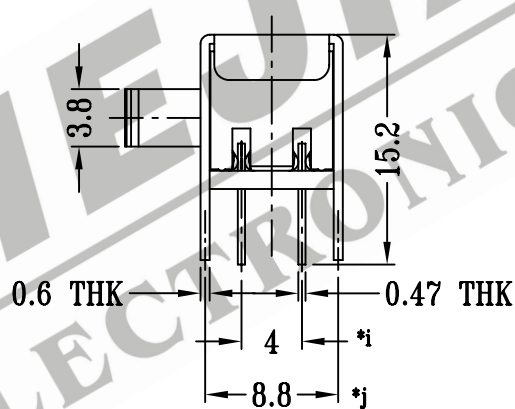
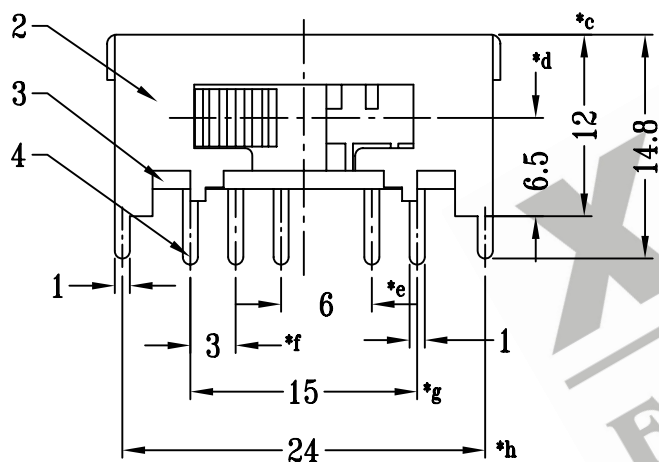

P.C.B LAYOUT

注:带"*"表示关键尺寸(10个)

NO.	PARTS	MATERIALS	Q'TY	FINISH	TOLERANCE UNLESS SPECIFIED	SHENZHEN XIEJIA ELECTRONICS CO.,LTD.					
8						TITLE : HORIZONTAL L SLIDE SWITCH		UNIT : mm	DRWG NO.: XJ-DR-SK24F01-00		
7	STEEL BALL	STEEL	1	NATURAL	WITHIN: 1.5 ±0.1mm	MODEL: SK-24F01		SCALE: 2:1	DWN.	ZHOUYU	2005-9-23
6	SPRING	STAINLESS STEEL	1	TEMPER	OVER: 1.5 ±0.2mm				CHK'D	FANGYING	2005-9-23
5	CONTACT (CLIP)	PBS STRIP	2	Ag PLATED		ISSUE	DATE	DESCRIPTIONS OF REVISION		APPD.	
4	TERMINAL	BRASS STRIP	10	Ag PLATED OVER Ni PLATED					APPD.	KANGXINAN	2005-9-23
3	TERMINAL BASE	PHENOLIC RESIN	1	BLACK							
2	FRAME	STEEL STRIP	1	Ni PLATED							
1	KNOB	POM	1	BLACK							
					ALL MATERIALS MUST BE COMPLIANT TO ROHS						